

SERVER

• E S S E N T I A L S •

Touchless Server Express® Featuring PerfectSense™ Technology

Used with pouches up to
1½ gallons with 16mm
fitments.

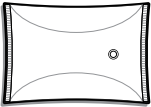

MODELS:

SE-SS-T

SE-SS-TDI

SE-3-T

SE-3-TDI

SE-5-T

SE-5-TDI



Thank You

for purchasing our Touchless Server Express® Pouched Condiment Dispenser. This portion controlled unit is sealed and sanitary, achieves excellent evacuation and has only a few parts for easy clean-up.

SIMPLIFY CONDIMENT MANAGEMENT— GO TOUCHLESS

TABLE OF CONTENTS

AVAILABLE MODELS.....	3
DROP-IN UNIT INFO.....	4
PUMP PARTS BREAKDOWN.....	4
COMPLETE PARTS BREAKDOWN.....	5
SAFETY INFORMATION.....	6
FLAVOR DECAL INSTALLATION.....	6
PUMP ASSEMBLY.....	7
SETUP.....	8
HOW TO OPERATE.....	10
SENSOR LIGHT.....	11
TAKE-DOWN & DISASSEMBLY.....	12
CLEANING.....	13
TROUBLE SHOOTING.....	14

TOUCHLESS EXPRESS™ MODELS

SE-SS-T

100257 - USA MARKET

100366 - EXPORT

100451 - EURO

100452 - AUST

100572 - UK

Single



SE-SS-TDI

100258 - USA MARKET

100368 - EXPORT

100453 - EURO

100454 - AUST

100573 - UK

Single Drop-In



SE-3-T

100468 - USA MARKET

Triple



SE-3-TDI

100469 - USA MARKET

Triple Drop-In



SE-5-T

100493 - USA MARKET

Quintuple



SE-5-TDI

100446 - USA MARKET

Quintuple Drop-In



DROP-IN UNITS

Drop-in unit can be used either on a countertop surface or can be dropped into an opening in a countertop.



MODEL NUMBER

RECOMMENDED COUNTERTOP OPENING SIZE

100258 / 100368
100453 / 100454 /
100573

6 3/8" x 8 1/2"

100469

16 3/8" x 8 1/2"

100446

27 3/16" x 8 1/2"

PUMP MODEL 100264

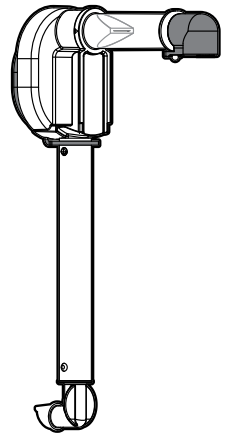
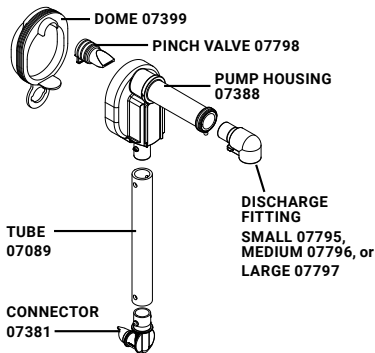

POWER SUPPLY/CORD

Power Supply/Cord 100273 (100-240V NEMA 5-15)

Models: 100257, 100366, 100258, 100368, 100468, 100469, 100493 & 100446



Power Supply/Cord 100418 (100-240V AUST)

Models: 100452 & 100454



Power Supply/Cord 100417 (100-240V UK)

Models: 100572 & 100573



Power Supply/Cord 100605 (100-240V EURO)

Models: 100451 & 100453



PARTS - TOUCHLESS SERVER EXPRESS®

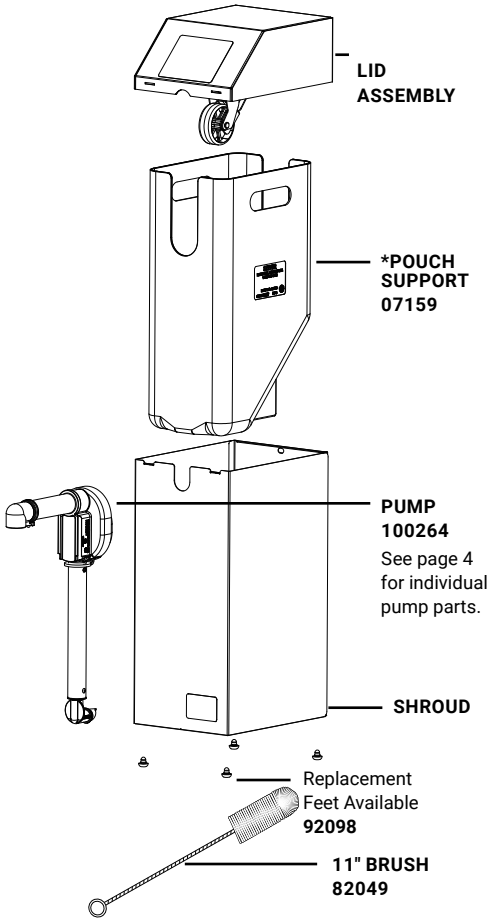

MODEL	REPLACEMENT LID ASSEMBLY
100257 / 100366 100258 / 100368	100295
100451 / 100452 100572 / 100453 100573 / 100454	100624
100468 / 100469	100465
100493 / 100446	100443

MODEL	REPLACEMENT SHROUD
100257 / 100366 100451 / 100452 100573	100297
100258 / 100368 100453 / 100454	100296
100469	100464
100468	100487
100493	100490
100446	100442

MODELS	REPLACEMENT SENSOR DIVIDER KITS/QTY NEEDED
100468 & 100469	100580 (1)
100493 & 100446	100580 (2)

Flavor Decal Sheet 100246



**For Express Singles, an 07159 pouch support may be substituted with a 100280 vessel. These parts are interchangeable and function the same.*



100280 VESSEL

SAFETY



WARNING-

ELECTRICAL SHOCK COULD OCCUR

This unit must be earthed or grounded.

This requires all three prongs (terminals) on cord plug to be plugged into power source.

Patent #: 10961105

US NEMA 5-15 plug models are UL listed.

Euro, UK & Australian plug models are CE listed.



According to food and safety regulations, most foods must be stored and/or served at certain temperatures or they could become hazardous. Check with local food and safety regulators for specific guidelines.

Be aware of the product you are serving and the temperature the product is required to maintain. Server Products, Inc. can not be responsible for the serving of potentially hazardous product.

IMPORTANT

Clean, rinse, sanitize, and dry parts daily or regularly to comply with local sanitization requirements.



NSF International lists this pump as: "Not acceptable for dispensing potentially hazardous foods."

ADA
compliant

FLAVOR DECAL INSTALLATION

Unit comes with a set of Flavor Decals to place on the unit for product identification. Peel appropriate flavor decal from sheet and place it carefully center and level right above the black User Interface Decal on the slanted surface of the lid.

Flavor Decal Sheet 100246



PUMP ASSEMBLY

WASH ALL PARTS PROPERLY BEFORE USE. See page 12.

- 1** INSERT PINCH VALVE into pump housing.

TIP: Squeeze the pinch valve open before installation to ensure it isn't stuck shut.

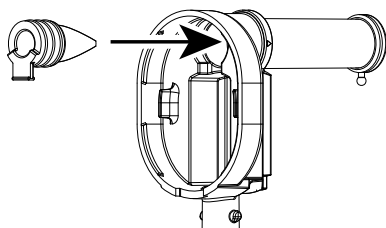

- 2** INSTALL DOME

Press dome into housing fully. Ensure valve flap covers bottom opening.

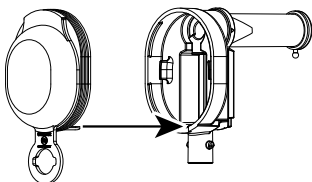

Wrap loop around lower opening to secure dome.

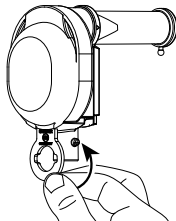

- 3** INSTALL TUBE

Lubricate with a small amount of clean water. Rotate and position until both pegs on housing fit into holes on tube.

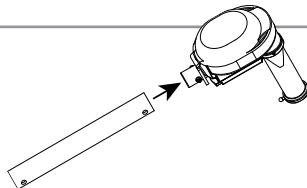

- 4** INSERT CONNECTOR

Lubricate with a small amount of clean water. Rotate and position until both pegs on connector fit into holes on tube. Connector must point away from end of discharge tube.

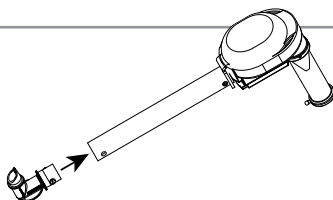

- 5** SELECT DISCHARGE FITTING

CONSISTENCY OF WHAT YOU DISPENSE

SUGGESTED FITTING SIZE

THIN (hot sauce)..... SMALL
 THICK (ketchup or mustard)..... MEDIUM
 THICKER (relish or tartar sauce)..... LARGE

Fittings are marked small, medium or large on bottom.

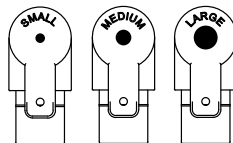

- 6** INSERT DISCHARGE FITTING

into pump housing discharge tube. Place loop of fitting around peg on end of discharge tube to secure.

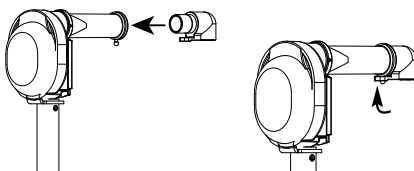

SETUP



PRACTICE SAFETY.

WASH ALL PARTS PROPERLY BEFORE USE. See page 11.

IMPORTANT!

Before first use and periodically throughout operation, clean sensor window with a microfiber cloth to keep it free of debris in order to function properly.



1 ATTACH POUCH TO PUMP

Firmly press piercing connector into center of pouch fitting.

An audible click indicates a secure connection.

TIP: Prime the pump. Push the dome to draw food up towards the discharge tube.

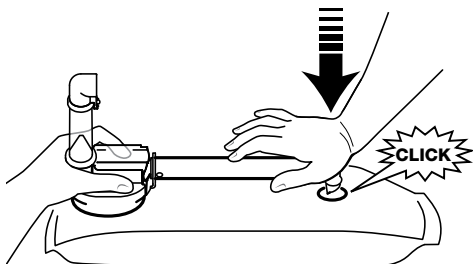

2 INSTALL PUMP

Slide pouch and pump into pouch support within shroud.

Align pump guides into slots in shroud.

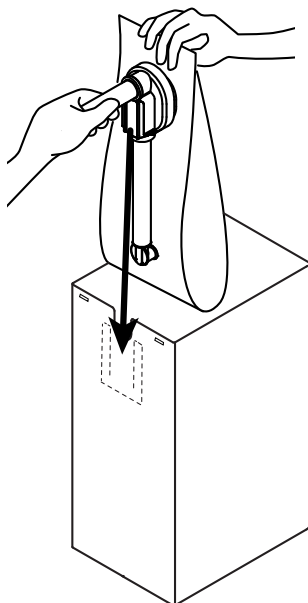

3 PLACE LID ON TOP

Align slots on front of lid with tabs on front of shroud and pull locking spring pin out on back of lid and push down into locking position. Release locking spring pin to lock into position.



Placing lid on shroud



Aligning lid slots with shroud tabs



For single units, pulling locking spring pin out to lock the back of the lid into position



For multiple units, secure lid latches on both sides of the lid

4 PLUG UNIT INTO POWER SOURCE

Make sure power inlet supply connector is plugged into the back of the lid and to plug cord into the power supply and into the outlet.



Inlet supply connector being plugged in



Cord plugged into the power supply

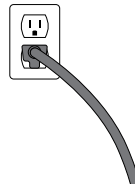

5 TURN UNIT ON

Press switch on back of lid to the on position.



6 PRIME PUMP

If you did not prime pump before installing the pump and pouch, you can do so by either pressing the manual dispense button or actuate the auto dispense sensor until product fills the discharge tube.

AUTO DISPENSE

Hold hand over sensor window for touchless operation.

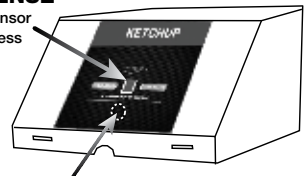

MANUAL DISPENSE

To prime pump or dispense manually, press area below sensor window.



Pump primed with food product seen in discharge tube.

HOW TO OPERATE

TOUCHLESS DISPENSE

Place one hand over sensing window while holding portion cup or food item underneath dispensing point.



HOW IT WORKS

- The sensing window detects your hand 1" to 3" away from the surface of the window.
- Unit will not dispense product if cleaning the surface of the sensing window because it's within 1".
- If hand is held through an entire dispense cycle, the dispenser will dispense approximately 1 oz of product and then stop. You will need to pull your hand away and then replace hand back over the sensing window to start another portion.
- If hand is pulled away prior to a full cycle, the unit will stop dispensing and the portion will be less than 1 oz.

MANUAL DISPENSE

For manual dispense to prime, press the area below the sensor window.

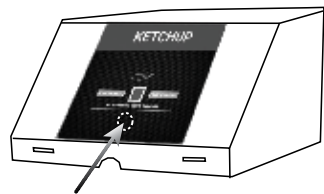

MANUAL DISPENSE

To prime pump or dispense manually, press area below sensor window.

SENSOR LIGHT

WHAT DO THE DIFFERENT SENSOR LIGHT COLORS MEAN?

- Sensor light color sequences at time of dispenser power up. First there will be a blue sensor light that will flash, then a green sensor light, then a red sensor light and finally a blue sensor light that will appear and stay lit, indicating the dispenser is in a ready state to begin dispensing.
- A green sensor light will appear when the sensor is triggered by a break in the sensing "beam" (hand over sensor). It stays green through the dispensing cycle and won't turn back to blue until the sensing "beam" is clear (remove hand).
- A red sensor light will appear if a dispense cycle is interrupted before completion. The red light will stay on until the unit is reset. Reset the unit by powering the unit down and then powering the unit up again.
- A red sensor light that stays on or flashes on and off indicates that there may be a control board problem.
- If dispenser continues to run after any dispense cycle, this may indicate a problem with the cam switch.

WHAT IF THERE IS NO SENSOR LIGHT?

- Make sure power inlet supply connector is plugged into the back of the lid and that the cord is plugged into a power source and into the power supply all the way.



Inlet supply connector being plugged in



Cord plugged into the power supply

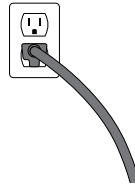

- Make sure the power switch on the back of the lid is pressed to the "On" position.



- Ensure that the lid is securely attached to the shroud and locked into place with the spring pin or lid latches. If lid is not securely tight and in the locked position, the cover safety switch release may not be fully engaged and the unit will not power up.
- If the electrical system or gearmotor fails, there will be no light on at all. If this happens or the dispenser stops working for some reason and you rule out the power supply, turn the power switch to the "Off" position, unplug the power inlet supply connector from the back of the lid for 5 seconds and then plug the connector back into the power inlet and then power the switch to the "On" position. This sequence of operations will make the mechanical and electrical system reset the system to the home or start position.
- No sensor light at any time may indicate a control board problem.

TAKE-DOWN & DISASSEMBLY

1 POWER DOWN

Turn power switch to the "Off" position and unplug unit from the power source.

2 REMOVE LID

For single units, pull locking spring pin out on the back of the lid and pull lid up then slide the lid forward to disengage lid slots from the shroud tabs on front of the unit.

For multiple units, release locking latches on both sides of lid and pull lid up then slide the lid forward to disengage lid slots from the shroud tabs on front of the unit.



For singles, pull locking spring pin out to unlock the back of the lid



For multiples, release locking latches prior to removing lid

3 REMOVE PUMP & POUCH

4 DETACH PUMP FROM POUCH

5 FLUSH & RINSE PUMP

Place lower end of pump into container of hot water. Pump until all remaining product is expelled and only water flows from discharge tube.

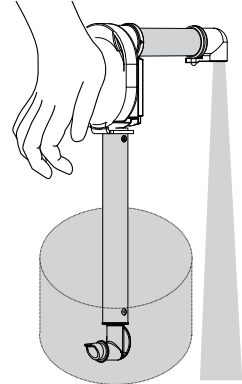

6 DISASSEMBLE

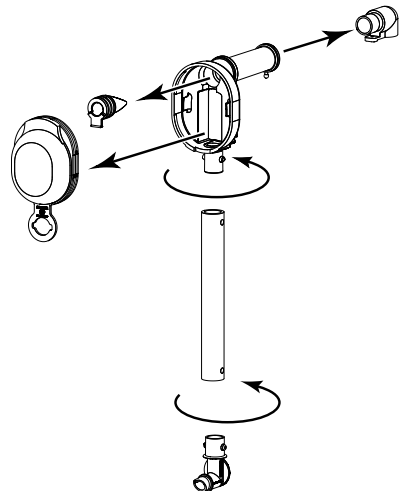
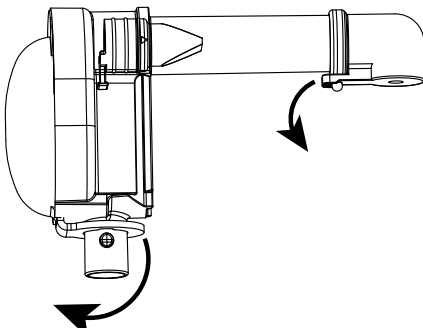

CLEANING

WARNING- **ELECTRICAL SHOCK COULD OCCUR**

- Electrical components of unit could be damaged from water exposure or any liquid.
- Never immerse lid into water or any liquid.
- Never use any water jet or pressure sprayer on lid.
- Ensure unit is "OFF" and unplugged.

Pump 100264

1 CLEAN
Remove lid and pull out pump. After disassembling pump, clean all parts with soap and hot water.

2 RINSE
fully with clear water.

3 SANITIZE
all parts according to local sanitization requirements. All parts in contact with food must be sanitized.

4 AIR DRY
all parts fully.



YES!

Use dishwashing soap and hot water

- External surfaces may be wiped clean with a clean damp cloth.
- Dry all parts fully with a clean soft cloth.
- Glass and surface cleaners approved for use in food contact areas may be used.
- Do not use abrasive, caustic or ammonia based cleansers.
- Do not use metal scrapers or cleaning pads that could scratch surfaces.

IMPORTANT!

Periodically clean sensor window with a microfiber cloth to keep it free of debris in order to function properly.



CARE OF STAINLESS STEEL

This unit is constructed with stainless steel— one of the best materials for food serving and storage.

If you notice corrosion beginning on any stainless steel surface, you may need to change the cleansing agent, sanitizing agent, or the cleaning procedures you are using.

- A mildly abrasive nylon or brass brush may be used to remove any stubborn food or mineral deposits on interior surfaces of unit.
- Fully rinsing and drying all parts can help prevent corrosion. Elements and minerals in tap water can accumulate on stainless steel parts and create corrosion.
- Do not use products containing acids, alkalines, chlorine, or salt. These agents can corrode stainless steel.

TROUBLESHOOTING

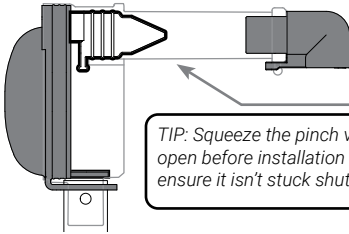

UNIT DOES NOT TURN ON?

- Ensure power inlet supply connector is plugged into the back of the lid.
- Make sure to plug cord into power supply.
- Ensure power is available from source.
- Ensure power switch is on the "On" position.
- If still not working, turn the power switch to the "Off" position, unplug the power inlet supply connector from the back of the lid for 5 seconds, then plug it back in and turn the power switch to the "On" position. This makes the mechanical and electrical system reset to the start position.
- Ensure lid is fastened to shroud with spring pin(s).

UNIT DISPENSES ERRATICALLY

- Ensure sensor window is clean of debris or water and the window film is not damaged or scratched.

DIFFICULT TO ATTACH PARTS?

- Wet parts with clean water to help fit.

PRODUCT DOESN'T PUMP?

- Ensure pinch valve is inserted in housing.
- Ensure connector is snapped fully in place to fitment in pouch.
- Ensure pump is properly attached to pouch.
- Clean pump thoroughly.
- Ensure pump is properly installed into retaining slots inside front wall of shroud.

DOMES POP OFF?

- Clean thoroughly. Food residue could prevent a tight seal between dome and housing.
- Ensure dome edges are flush with housing.

UNIT TRIPS THE BREAKER? (GROUND FAULT INTERRUPTER)

- Never expose electrical components to water or liquid. This may result in damage. Unit may not function.

If electrical components have gotten wet:

- Turn off unit and unplug.
- Allow unit to dry completely.

SERVER PRODUCTS LIMITED WARRANTY

1
YEAR
WARRANTY

This Server product is backed by a two-year limited warranty against defects in materials and workmanship. See Server-Products.com for details.

GENERAL SERVICE, REPAIR OR RETURNS

Before sending any item to Server Products for service, repair, or return, contact Server Products customer service to request a **Return Authorization Number**. Merchandise must be sent to Server Products with this number. Service is extremely prompt. Typically, units are repaired and ship out within 48 hours of receipt.

Merchandise being returned for credit must be in new and unused condition and not more than 90 days old and will be subject to a 20% restocking charge.

NEED HELP?

Server Products Inc.

3601 Pleasant Hill Road
Richfield, WI 53076 USA

Chat with us!

spsales@server-products.com

262.628.5600 | 800.558.8722

Please be prepared with your **Model, P/N** and **Series** located on the lid or base of the unit.

Example:

MODEL XXXX P/N #####	NSF	SERIES ##X ##X
-------------------------------	-----	-------------------

SERVER
INTELLIGENT BY DESIGN